

INSTRUCTION MANUAL

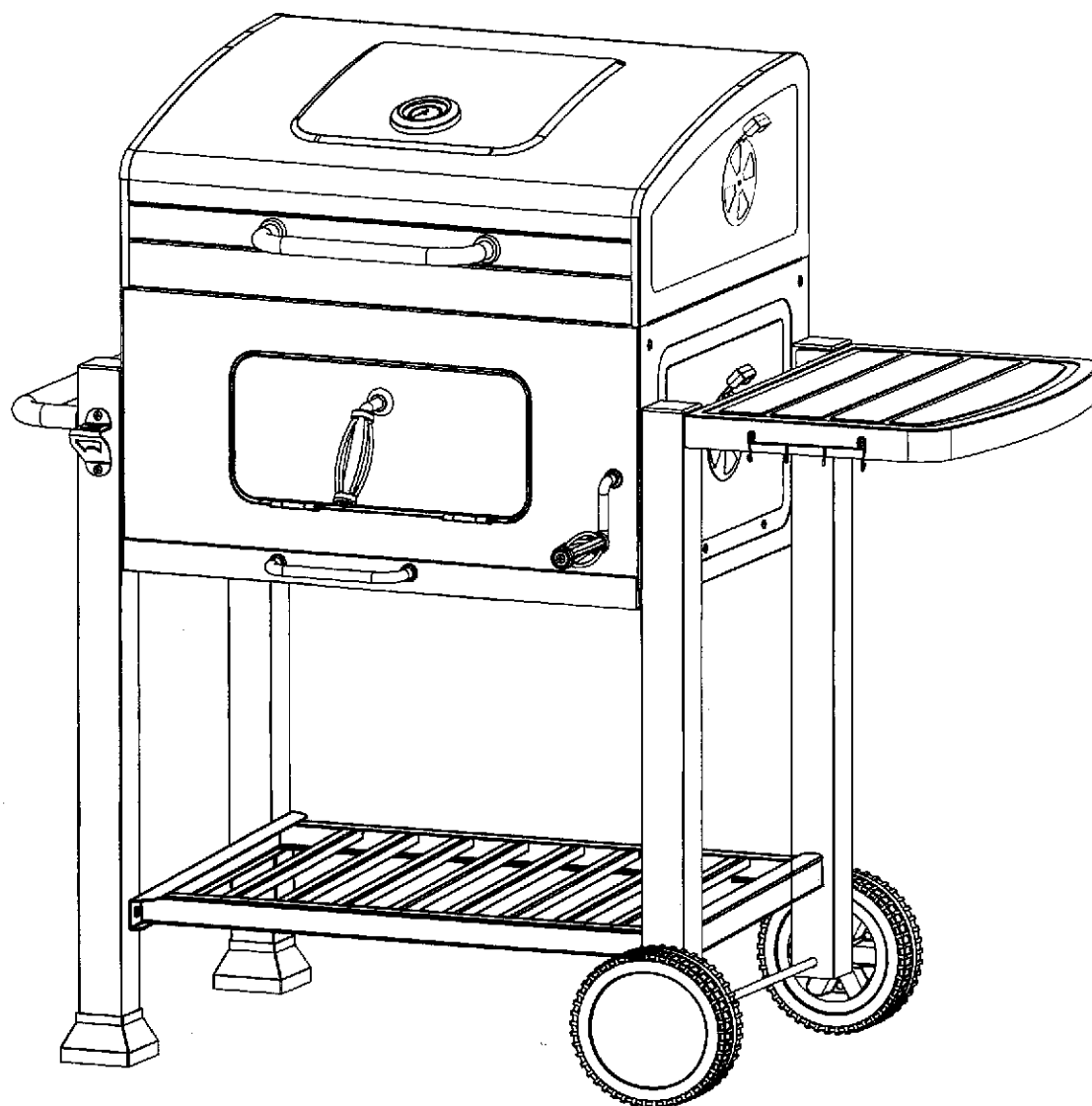

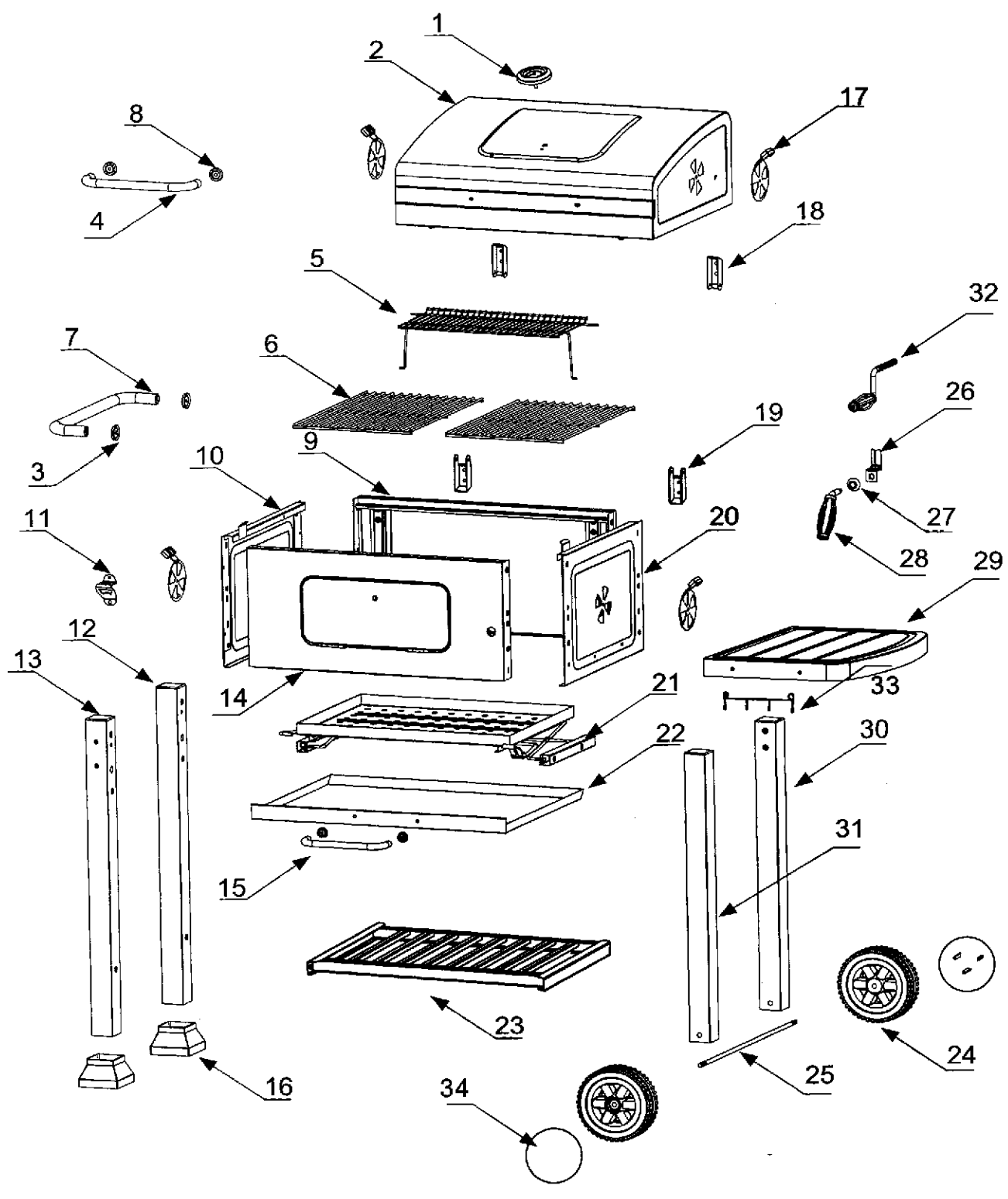









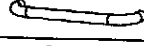







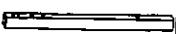
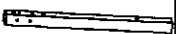

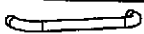







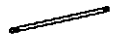

Cajun Charcoal BBQ
OL4524







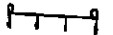



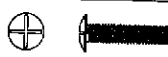

MADE IN CHINA



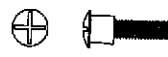









Parts

PART	PICTURE	DESCRIPTION	NUMBER
1		Thermometer	1
2		Lid	1
3		Handle spacer	2
4		Handle(lid)	1
5		Warming rack	1
6		Cooking grid	2
7		Handle(body)	1
8		Handle spacer for body	4
9		Back of the body	1
10		Side of the body	1
11		Bottle opener	1
12		Long leg	1
13		Long leg	1
14		Front of the body	1
15		Handle for ash pan	1
16		Rubber foot	2
17		Air vent	4
18		Hinge for lid	2
19		Hinge for body	2
20		Side of the body	1
21		Charcoal pan	1
22		Ash pan	1
23		Storage rack	1
24		Wheel	2
25		Axle	1
26		Support for handle (body gate)	1
27		Handle spacer (body gate)	1
28		Handle (body gate)	1
29		Side board	1
30		Short leg	1
31		Short leg	1
32		Handle for charcoal pan	1
33		Hook	1
34		wheel cap	2

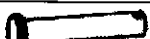
PART	PICTURE	DESCRIPTION	NUMBER
A	M6		11x
B	M6 X 12		20x
C	M6 X 20		12x
D	M6 X 40		12x
E	Ø6X40		3x
F			4x
G	M6 X 20		4x
H	M6 X 80		2x
I	M10		2x
J	Ø6X12		1x
K	Ø6X16		1x

Delar

Del	Bild	Benämning	Antal
1		Thermometer	1
2		Lock	1
3		Hantera spacer	2
4		Hantera (Lock)	1
5		Uppvärmningen rack	1
6		Grillgaller	2
7		Hantera (Kroppen)	1
8		Hantera spacer (Kroppen)	4
9		Baksidan av kroppen	1
10		Sidan av kroppen	1
11		Öppnare	1
12		Lång ben	1
13		Lång ben	1
14		Framsidan av kroppen	1
15		Hantera (Askfat)	1
16		Gummi fot	2
17		Luftventil	4
18		Gångjärn (Lock)	2
19		Gångjärn (Kroppen)	2
20		Sidan av kroppen	1
21		Träkol pan	1
22		Askfat	1
23		Lagring rack	1
24		Hjul	2
25		Axle	1
26		Hantera supporter(Gate)	1
27		Hantera spacer (Gate)	1
28		Hantera (Gate)	1
29		Side board	1
30		Kort ben	1
31		Kort ben	1
32		Träkol pan justering	1
33		Krok	1
34		Hjul täcka	2

Del	Benämning	Bild	Antal
A	M6		11x
B	M6 X12		20x
C	M6 X20		12x
D	M6 X40		12x
E	Ø6X40		3x
F			4x
G	M6 X20		4x
H	M6 X80		2x
I	M10		2x
J	Ø6X12		1x
K	Ø6X16		1x

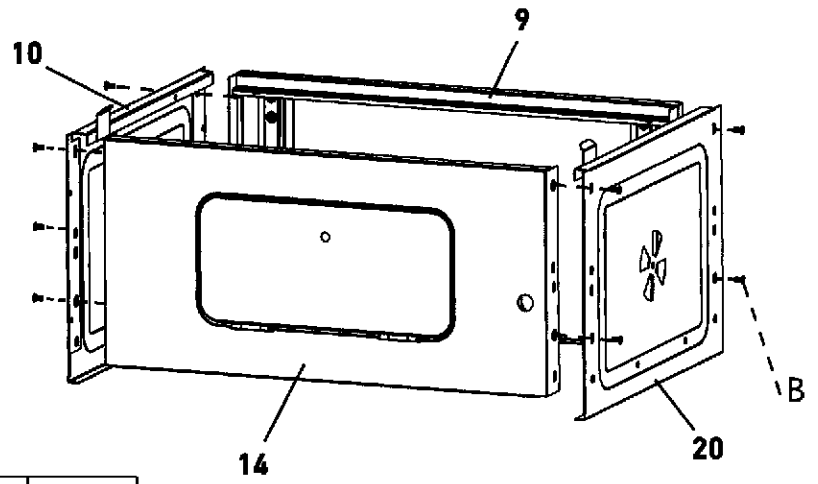

Step 1

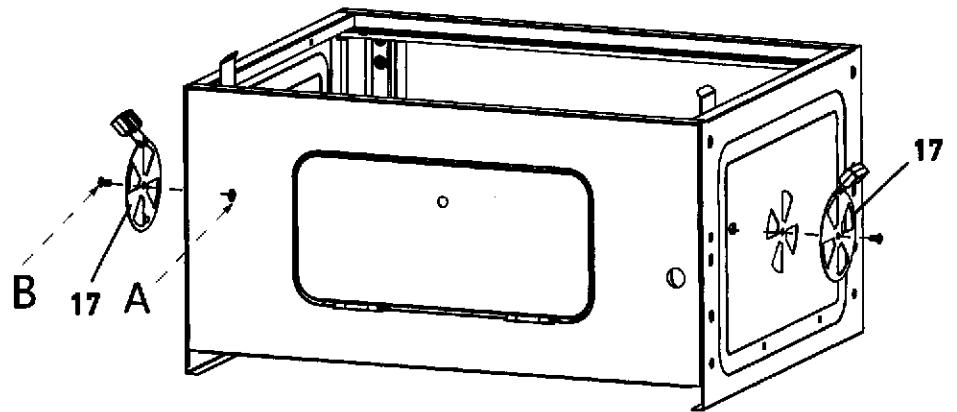

PART	PICTURE	DESCRIPTION	NUMBER
B		M6X12	8

Step 2



PART	PICTURE	DESCRIPTION	NUMBER
B		M6X12	2
A		M6	2

Step 3

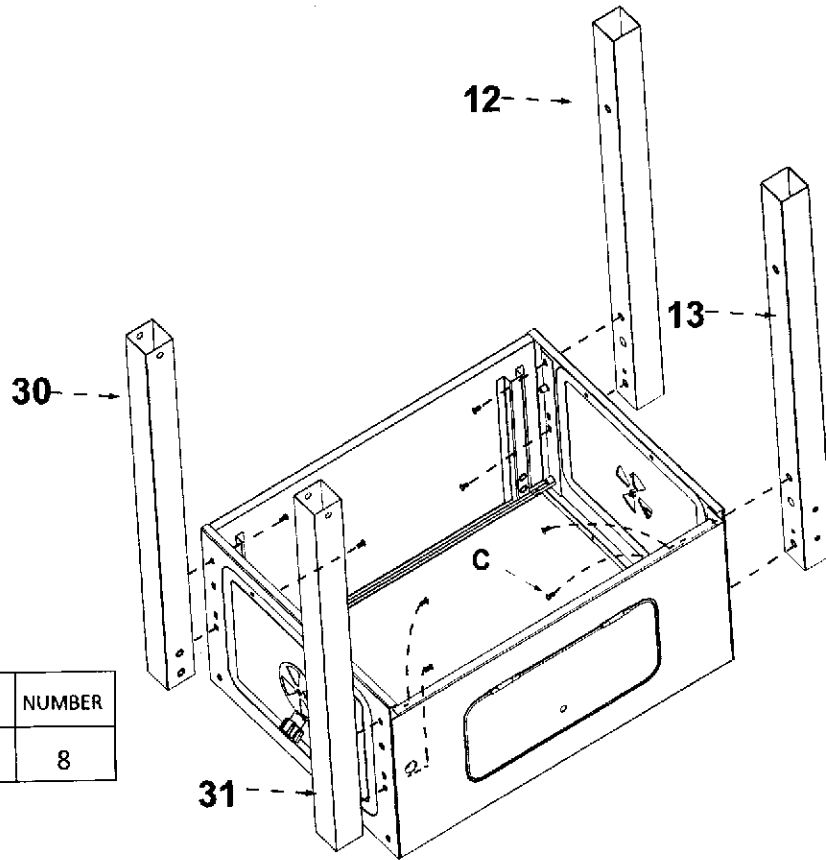

PART	PICTURE	DESCRIPTION	NUMBER
C		M6X20	8

Step 4

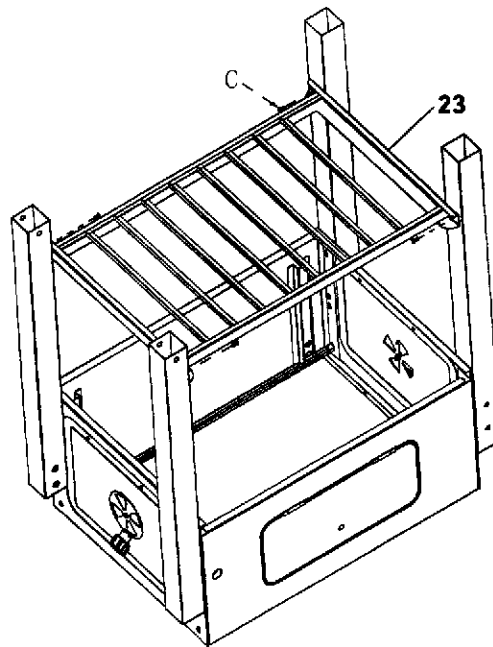

PART	PICTURE	DESCRIPTION	NUMBER
C		M6X20	4



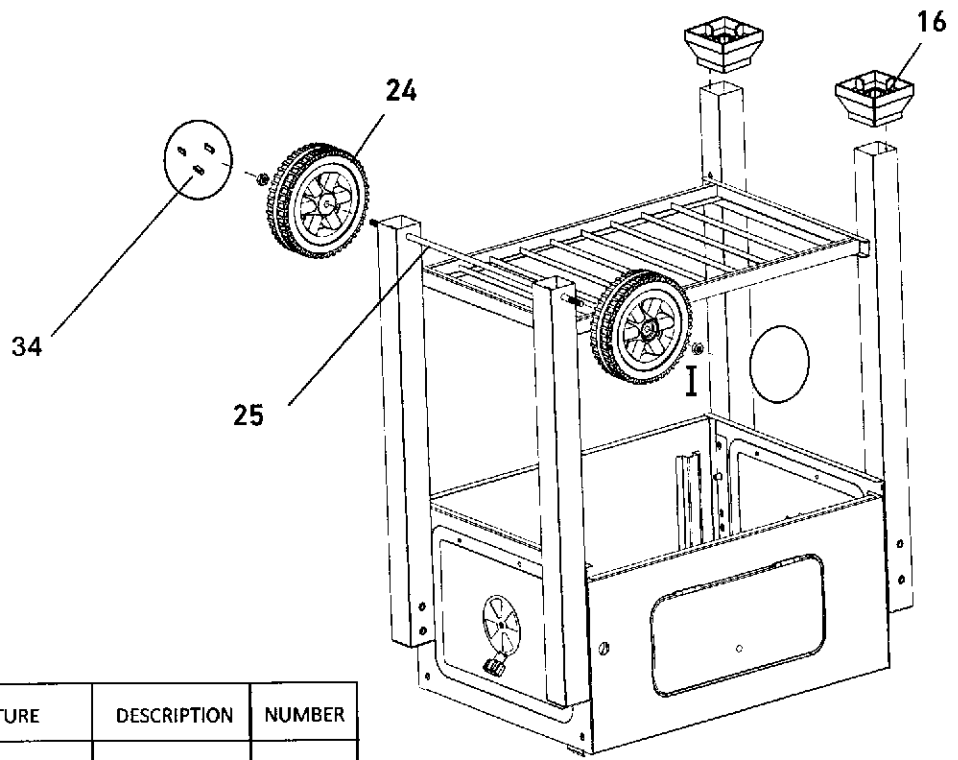

Step 5

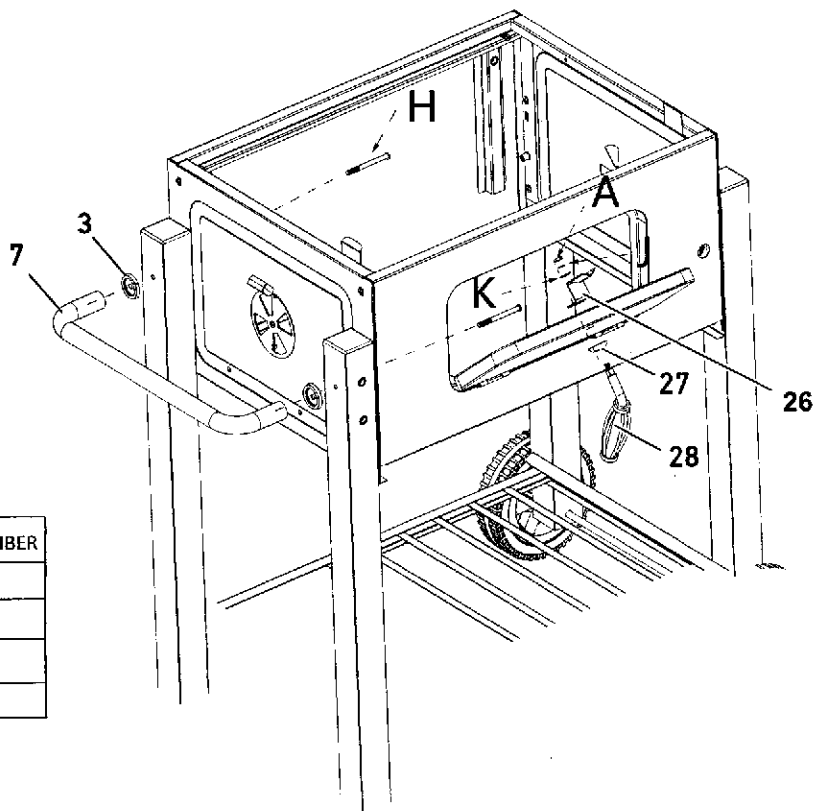

PART	PICTURE	DESCRIPTION	NUMBER
I		M10	2

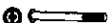
Step 6



PART	PICTURE	DESCRIPTION	NUMBER
H		M6X80	2
A		M6	1
K		Ø6X16	1
J		Ø6 X 12	1

Step 7

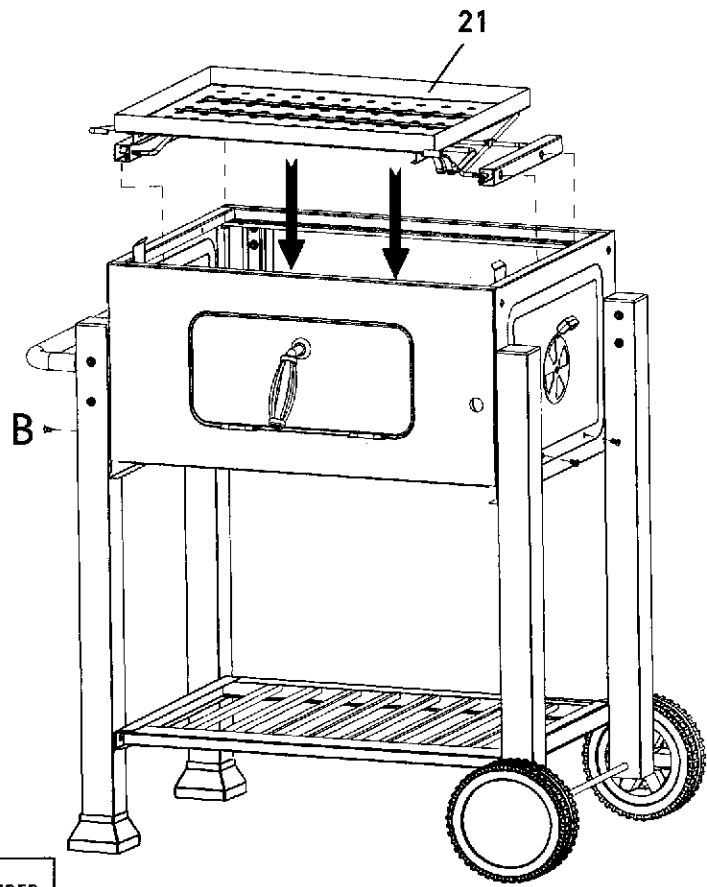

PART	PICTURE	DESCRIPTION	NUMBER
B		M6X12	4

Step 8

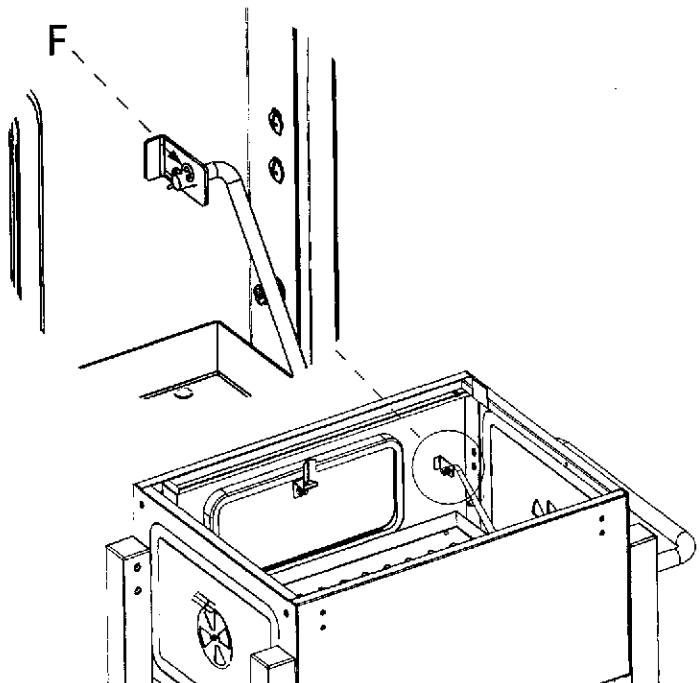

PART	PICTURE	DESCRIPTION	NUMBER
F			1

Step 9

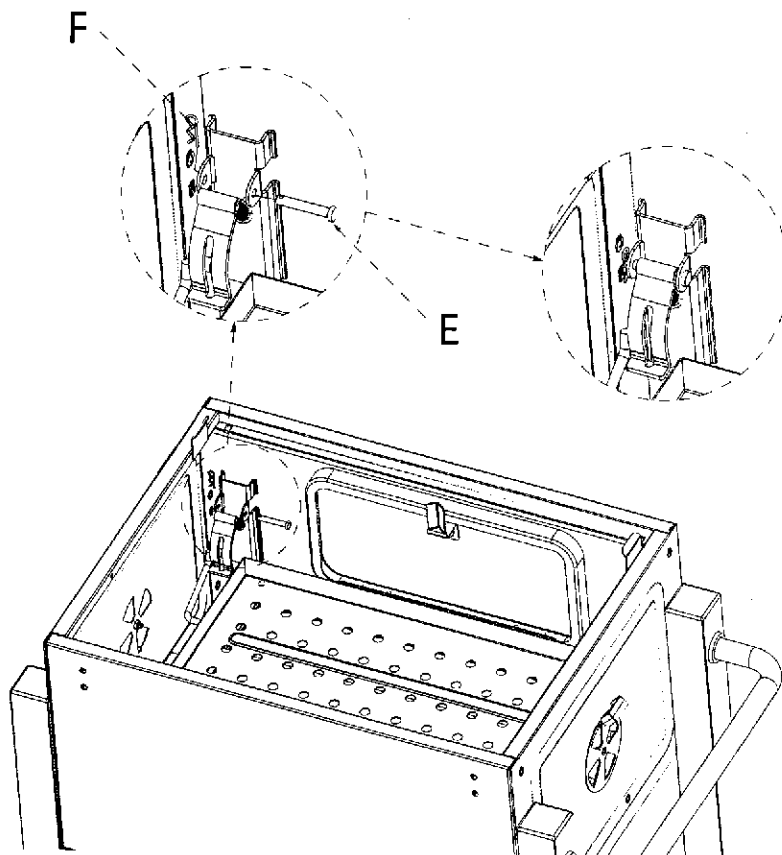

PART	PICTURE	DESCRIPTION	NUMBER
E		∅6X40	1
F			1

Step 10

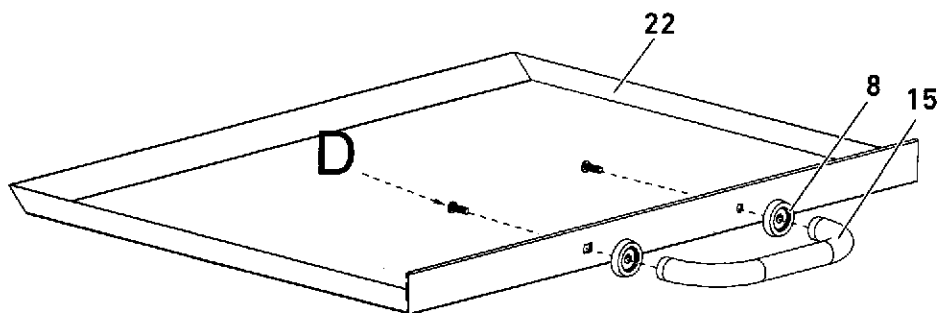

PART	PICTURE	DESCRIPTION	NUMBER
D		M6X40	2

Step 11

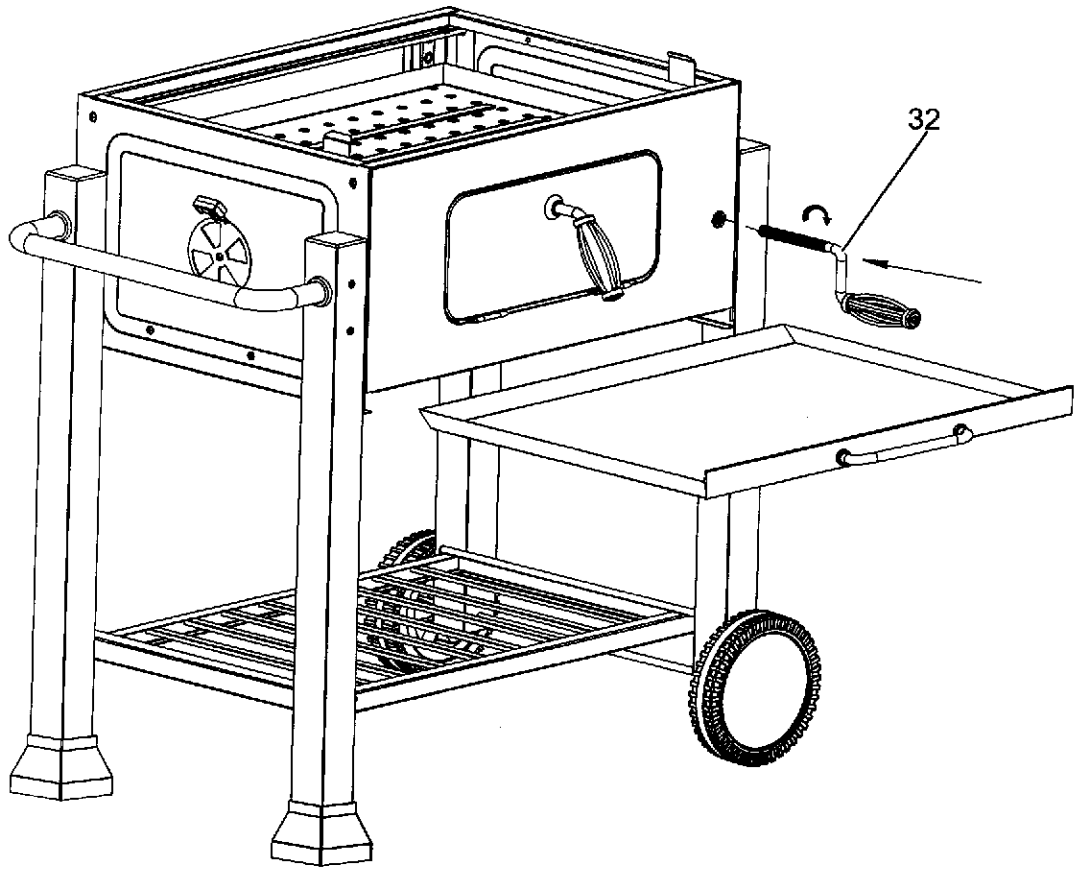

Step 12

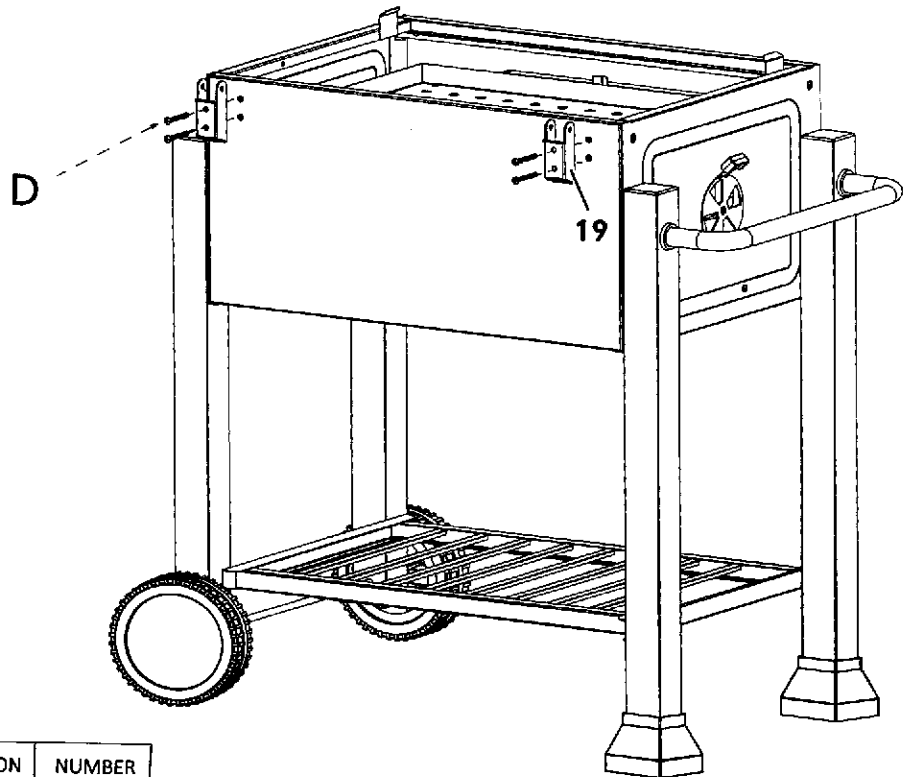

PART	PICTURE	DESCRIPTION	NUMBER
D		M6X40	4

Step 13

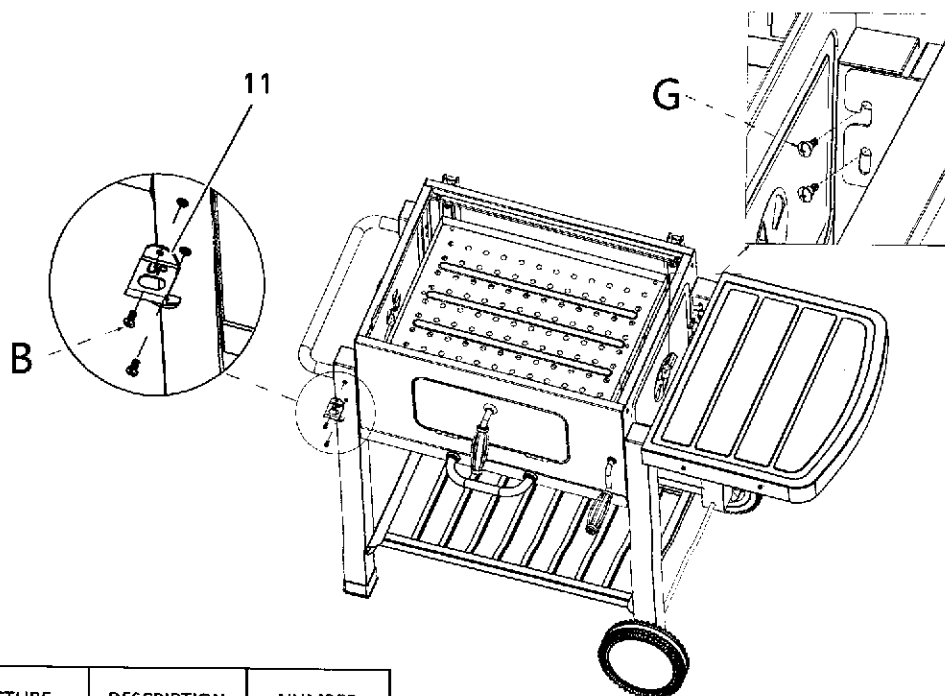

PART	PICTURE	DESCRIPTION	NUMBER
B		M6X12	2
G		M6x20	4

Step 14

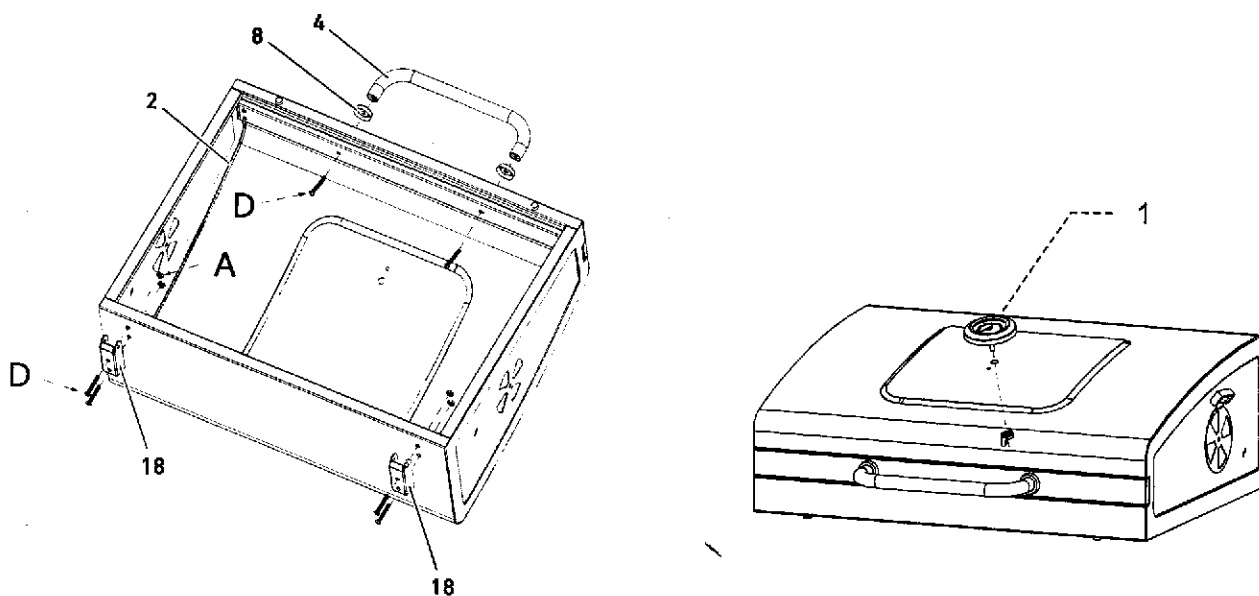

PART	PICTURE	DESCRIPTION	NUMBER
D		M6X40	6
A		M6	4

Step 15

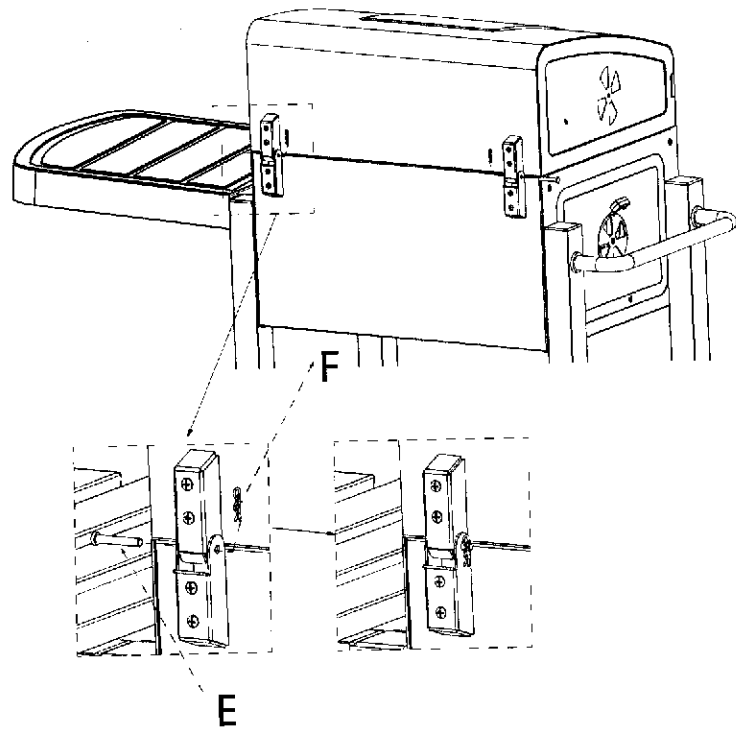

PART	PICTURE	DESCRIPTION	NUMBER
E		∅6X40	2
F			2

Step 16

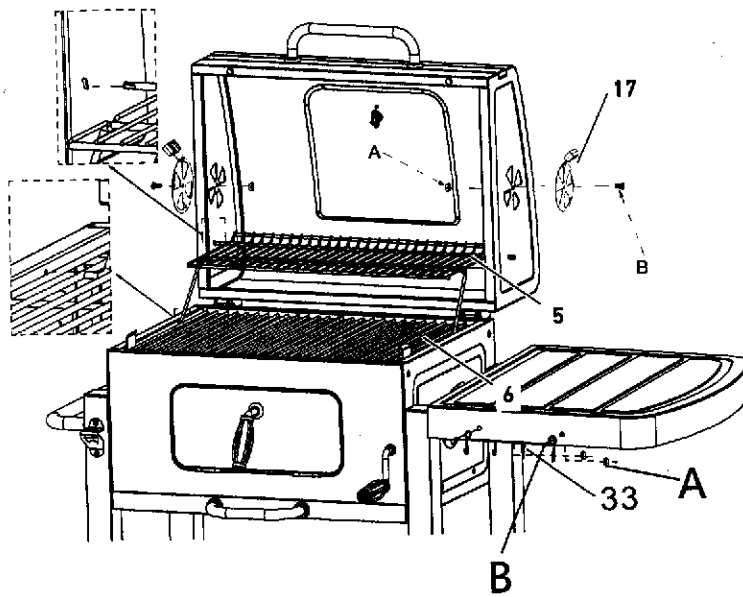

PART	PICTURE	DESCRIPTION	NUMBER
B		M6X12	4
A		M6	4